

THARO

PA1200

PRINTER/APPLICATOR

New, from the creators of **EASYLABEL®**, comes the **Tharo PA1200 Printer/Applicator**... A powerful accessory for direct thermal / thermal transfer bar code label printers.

Meet Demanding Applications with Maximum Uptime and Economical, Worry-Free Operation!

■ **Easy To Use** – The Tharo PA1200 Printer/Applicator is easy to use, with minimal adjustments necessary and quick setup and changeover for applying labels to either the top or side of the product. The PA1200 is also available in front apply, dual tamp and corner wrap configurations.

■ **Fast** – The PA1200 is quick and accurate, applying up to 60 labels per minute, depending on label size, printer used, and height of the products. A switching device, such as a foot switch, optical sensor or PLC (Programmable Logic Controller) can be connected to the applicator's PLC port to initiate the print and apply cycle. LEDs provide visual operating status and error conditions.

■ **High Compatibility** – By allowing for height, width, and depth adjustments, the compact PA1200 is specifically designed to be universally compatible with nearly any thermal transfer/direct thermal label printer.

■ **Cost-effective** – With minimal training, quick integration and increased personal productivity, the PA1200 provides a rapid return on investment.

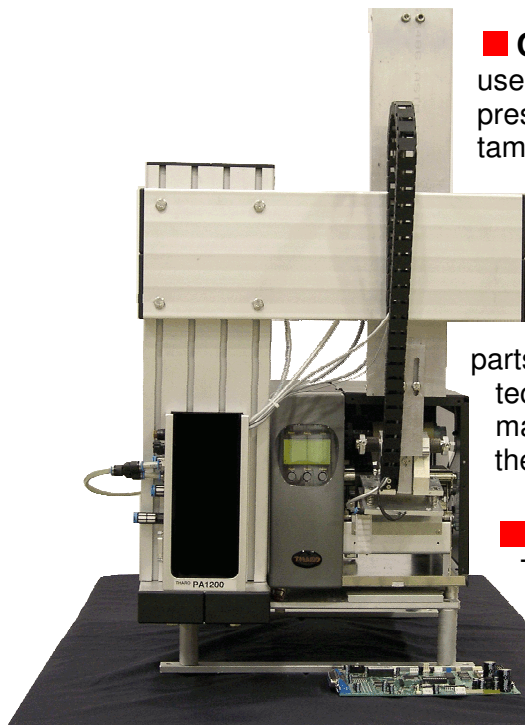

■ **Controlled Contact** – The use of springs and an adjustable pressure sensing switch on the tamp pad allows for very precise label placement and controlled contact.

■ **Easy To Service** – The small amount of moving parts, combined with the best technical support in the industry, makes maintaining and servicing the PA1200 quick and easy.

■ **Tremendous Accuracy** – The PA1200 is capable of label placement accuracy within 0.01" for stationary products, or 0.125" for moving products.

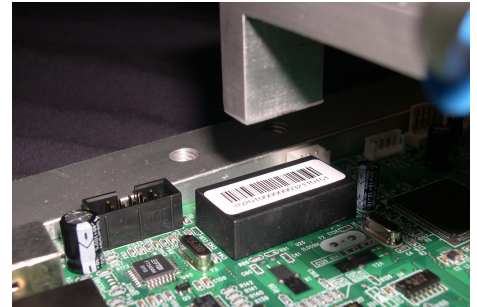

Specialty Tamp Alternative-

For situations where very small labels need to be applied, such as circuit board applications, the PA1200 supports custom Tamp sizes, which will permit labels as small as .20" wide x .20" high.

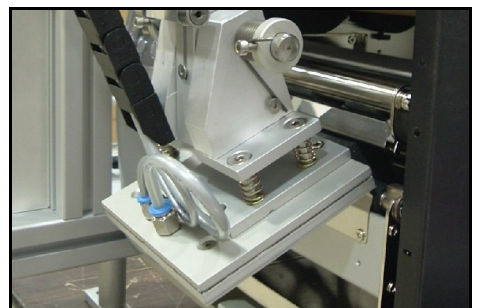

Tamp / Blow Alternative-

For those special jobs where a Tamp Applicator isn't appropriate, such as concave or convex objects, the Tharo PA1200tb will do the trick! The Tamp Pad stops between 1/2" and 2" from the product, then the label is blown on.

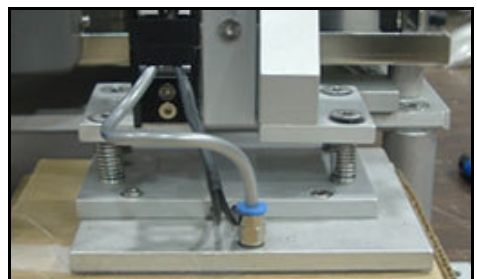

Standard Tamp Pad-

The customizable tamp pad comes pre-fitted with a nonstick plastic surface to suit your labeling needs.

OPTIONS



Warning Beacon -

The warning beacon functions as a visual display for applicator and printer errors. Can be used with all of the PA1200 variants.



Product Sensor -

The product sensor functions as an automatic trigger device, which sends a start signal to the applicator. Can be used with all of the PA1200 variants.



Foot Switch -

The foot switch functions as a manual trigger device, which sends a start signal to the applicator when it is pressed. Can be used on the Tamp, Tamp/Blow and Specialty Tamp variants of the PA1200.



Product Sensor Timer -

The product sensor timer is used to delay the application process. Can be used with all of the PA1200 variants.

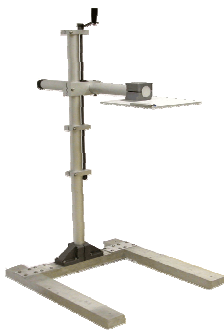

Hand Cranked Height

Adjustable H-base Stand -
Allows for extremely precise height adjustment, while providing stability, and allowing the PA1200 to be used with a conveyor or other automated system. Locking casters are available for the stand. Can be used with all of the PA1200 variants.



Table-top Stand -

Allows the PA1200 applicator to be placed on a table as an alternative to the H-Base Stand. Can be used on the Tamp, Tamp/Blow and Specialty Tamp variants of the PA1200.

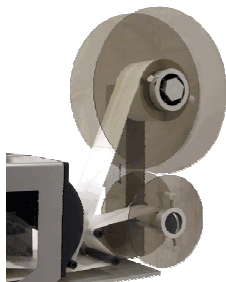

External Unwind/Rewind -

Accommodates up to 14" OD roll of label stock, and allows for quick replacement of media, which helps keep downtime to a minimum. Can be used on all variants of the PA1200 except the Specialty Tamp.

SPECIFICATIONS

Minimum Label Sizes

Specialty Tamp: .20" x .20" (5mm x 5mm)
Tamp: 2" x 1" (50.8mm x 25.4mm)
Tamp/Blow 3" x 1" (76.2mm x 25.4mm)
Dual Tamp/ Front Apply 3" x 1" (76.2mm x 25.4mm)

Maximum Label Size: 4.5" x 8.0" (114mm x 203mm) or 4.5" x 13" (114mm x 330.2mm) on the Corner Wrap.

Placement Accuracy: stationary: $\pm 0.01"$ (.25mm) or moving: $\pm 0.125"$ (3mm) (for example: conveyor belt applications)

Speed: Up to 60 labels per minute, depending on the printer, applicator, height of product, etc.

Weight of Applicator: 27lbs (12kg) – 37lbs (17kg)

Weight of Stand: 120lbs (55kg)

Standard Stroke Length: 17" total (432mm) (10" (254mm) below table) on the Tamp, Tamp/Blow and Specialty Tamp. Custom length cylinders are available upon request.

Swing Length: 26" (660.4mm) Swing on the Corner Wrap, Front Apply and Dual Tamp.

Air Requirement: 75 to 90 psi (5 to 6 bar)

Variable Height: Pressure Sensing Switch on the Tamp allows for labeling products of different heights without adjusting the applicator.

Printer Type: Direct Thermal/Thermal Transfer

Power Source: Switchable: 100V 60Hz or 230V 50Hz

Environmental: Temp 50-95°F (10-35°C) at 10-85% humidity

Standards: Built to CE safety and emissions standards.

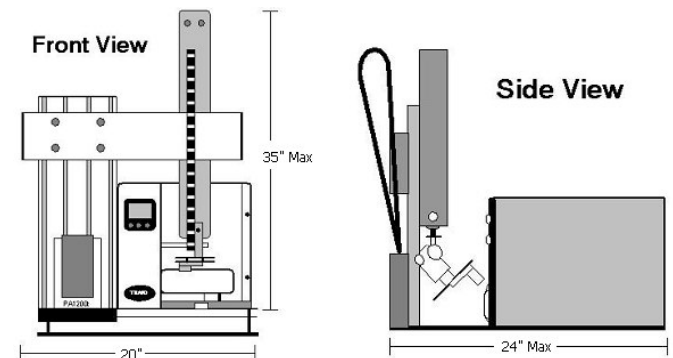

THE LABEL GUY

5198 Arlington Ave Suite 115, Riverside, CA 92504
951-340-0222 , 800-293-1813 Fax: 951-340-0005

www.TheLabelGuy.com

E-mail:sales@thelabelguy.com